

H₂Mare Update

02 / 2023



Online on 'offshore' mission

Build your own offshore wind farm and produce green hydrogen in a virtual marine environment: In the new browser game '**Offshore – the H₂Mare Game**', the curious can do just that – and playfully test the future technologies researched in H₂Mare on screen.

The aim of the game is to collect as many points as possible within a limited time. The amount of green hydrogen produced and its derivatives, completed orders from industry and environmentally friendly behaviour are all included in the score. Integrated tasks and quiz questions provide additional points and test players' knowledge. Current figures and research data from H₂Mare have been incorporated into the game to ensure scientific quality standards. Experts from the Hydrogen Flagship Project worked closely with the development team to achieve this. For an authentic experience, data on realistic weather conditions and environmental events was also incorporated.

The gaming approach is intended to get particularly younger people interested in future technologies. 'With our previous information measures, we primarily reach an adult specialist audience. Through gamification, we are also tailoring our offer to a young target group with an affinity for technology and encouraging their interest in the hydrogen and Power-to-X technologies developed in H₂Mare through fun and interaction', explains Dr. Klaus Litty, Group Manager Project Management and Coordination at Fraunhofer IWES and H₂Mare Project Manager.

'Offshore – the H₂Mare Game' can be played free of charge and without registration or prior installation at www.h2mare.info. It is compatible with the common browsers for desktop PCs as well as smartphones and tablets.

Dear readers,

From the laboratories, scientific papers and specialist journals, hydrogen technologies have taken their place in the heart of society. We at H₂Mare would also like to contribute to bringing offshore hydrogen technologies, some of which are still in a niche, into the public discourse and thus pave the way for safe and sustainable implementation. We have developed innovative approaches for this.

For example, we have set up an open scientific committee in which we discuss relevant topics on an interdisciplinary basis. This has since given rise to a handful of independent working groups that are specifically dedicated to overarching regulatory issues, acceptance and technical aspects, comparative analyses and calm management.

We are intensively analyzing which regulations are relevant for the offshore production of hydrogen and PtX products and are actively approaching stakeholders and authorities in order to work together on this as early as possible. By developing the technology and regulations hand in hand, subsequent approval processes should be made easier.

Involving and educating the affected population groups is of great importance to us. That is why we are particularly pleased about the publication of the 'Meer & Küste' magazine, which helps to inform particularly people along the coast and raises awareness of the potential but also the challenges of offshore green hydrogen production.

Our H₂Mare Game "Offshore" is undoubtedly a highlight and a completely different approach to making new offshore technologies and accompanying aspects such as environmental protection understandable. Here you can marvel at the future technologies researched and developed in H₂Mare virtually today and build your own offshore park – fun guaranteed. If this has whetted your appetite, why not try it out straight away?

Like this year, we will be organizing citizen dialogues and knowledge transfer events again in 2024 and will be represented at trade fairs and exhibitions. Take advantage of these opportunities to engage with us directly and raise your concerns and questions. Your perspectives are invaluable to us so that we can successfully advance our pioneering technologies - together with you.

Yours sincerely,
Hanna Dura
DECHEMA e.V.,
TransferWind coordinator



SPONSORED BY THE

'Meer & Küste' magazine gives H₂Mare insights

Fresh reading material for the offshore hydrogen community: H₂Mare project partner **EUCC – The Coastal Union Germany** has published the magazine 'Meer & Küste' (sea and coast). It also contains explanatory pieces, background articles and infographics on current H₂Mare research.

The topics discussed include the technical, spatial and economic requirements of green hydrogen produced at sea and its derivatives, the ecological impact of offshore wind turbines and questions of social acceptance. In the interview, H₂Mare coordinator Matthias Müller also talks about when offshore technology could become a reality and how it can help us become less dependent on traditional fossil fuel suppliers.

The magazine is aimed in particular at the population of the north German coast and guests, but also appeals to school classes and experts from universities, authorities and associations. It is available free of charge at numerous tourist information offices, youth hostels, museums, (environmental) educational institutions, scientific institutions and authorities in northern Germany as well as online at www.eucc-d.de (German only).

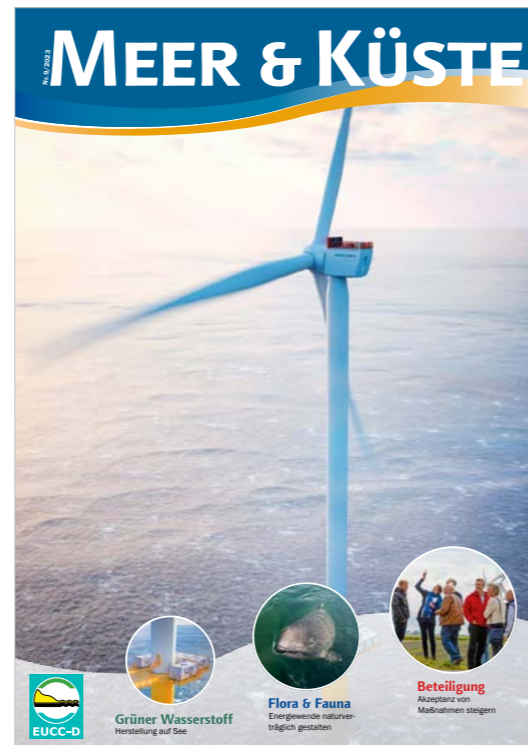

© EUCC-D/Siemens Gamesa

'Meer & Küste' magazine gives H₂Mare insights

Strengthen the acceptance of offshore technologies

Educating the public about the opportunities and challenges of the offshore technologies being researched in H₂Mare in order to create understanding and acceptance – that is the core concern of the H₂Mare acceptance working group.

At the last meeting, led by Dr. Laura Schmidt (**Helmholtz-Zentrum Hereon**) and Marlen Sunnyi Bohne (**Foundation OFFSHORE WIND ENERGY**), the members of the working group developed ideas for possible communication events and measures, classified stakeholder groups within a stakeholder matrix and provided input for topics and the further development of planned focus groups.

The overarching aim of the working group is to sensitize and inform the project partners about the topic of acceptance, which is central to a successful energy transition, and ultimately to enable them to integrate methods and approaches into their own project work. Participation is open to all H₂Mare project partners. The initiative is led by the Foundation OFFSHORE WIND ENERGY, the Helmholtz-Zentrum Hereon, the EUCC – The Coastal Union Germany, DECHEMA and Fraunhofer IWES.



© Stiftung OFFSHORE-WINDENERGIE

Members of the acceptance working group discuss at their first workshop in Frankfurt in June 2023

H₂Mare partners explore regulatory framework for offshore hydrogen

What legal framework already exists for offshore platforms on which hydrogen or other Power-to-X products are produced – and where is there still a need for further development?

The topic of regulation plays a key role in H₂Mare, for example for the regulated and safe construction and operation of the offshore platforms developed in H₂Mare. In order for the systems to be approved, the developers need basic information on the requirements. In particular, design and environmental law aspects must be taken into account in the design and operation. There are currently still legal uncertainties here, which are hampering technology development and the market ramp-up.

These uncertainties were jointly identified and addressed in a workshop organized by H₂Mare project partner **cruh21**. In the process, it was possible to compile a number of requirements for setting incentives for the initiation of offshore hydrogen projects and with regard to the prerequisites for project approval.

The topic is current due to the so-called 'Sonstiger Energieerzeugungsbereich' (other energy generation area, SEN-1) in the area development plan for the North Sea of the Federal Maritime and Hydrographic Agency. Companies or consortia can apply to realize Germany's first offshore hydrogen project in this area in a future tendering process.



© Siemens Gamesa

Symbolic image of an offshore wind farm

New H₂Mare advisory board provides impetus

© H₂Mare/Dirk-Oliver Schmidt

The participants of the H₂Mare advisory board meeting in Berlin

On November 14, 2023, the participants of the first physical H₂Mare advisory board meeting in Berlin followed in the footsteps of Federal Chancellor Scholz and Federal Minister of Economics Habeck. Just a few days after the official opening, they were able to see the new gigawatt factory for electrolyzers for themselves during a factory tour with host and H₂Mare project partner **Siemens Energy**. Afterwards, the advisory board and the coordination team discussed the status of the project as well as current and upcoming challenges in H₂Mare.

'We would like to thank our advisory board members for the intensive discussions and valuable suggestions, including for even more active

communication of our activities and results to various stakeholder groups', summarizes project coordinator Matthias Müller.

The H₂Mare advisory board held its inaugural meeting in July 2023. It consists of seven external experts from various specialist areas: Dr. Thorsten Hauck (VDEh Betriebsforschungsinstitut), Prof. Dr. Andreas Löschel (Ruhr University Bochum), Sybille Riepe (Motum GmbH), Jörg Singer (Aqua Ventus Förderverein e.V.), Stefan Thimm (BWO), Dr. Finn Andreas Viehberg (WWF Germany) and Dr. Kirsten Westphal (BDEW). They advise H₂Mare on the strategic direction of research topics, for example, and provide a view beyond the project horizon.

Review of the second half of 2023

>>>

H₂Mare presents itself

In the second half of 2023, H₂Mare went on an event tour. In August, the project was invited by the Federal Ministry of Education and Research (BMBF) to present itself to young and old at the Open Day in Berlin. Further stops included trade fairs, together with colleagues from the lead projects H₂Giga and TransHyDE, in September in the north (Husum Wind), in November in the west (European Hydrogen Week in Brussels) and in December in the south (Hydrogen Dialogue in Nuremberg). Experts from the project were able to answer many questions on the status quo of the research work, provide exclusive insights into the project and ultimately benefit from the valuable exchange themselves. Below you will find some impressions.



Thumbs up for the Flagship Projects

© Andrei Salavei

European Hydrogen Week, Brussels



H₂Mare was well-represented by colleagues from all joint projects at the Hydrogen Flagship Projects booth in Brussels

© Ulrike Möllmert



© H₂Mare

Open house BMBF Berlin



OffgridWind coordinator Thomas Schwabe presented the model of an offshore wind turbine with electrolyser at the H₂Mare booth

© H₂Mare/Christian Hiemisch



Under the motto 'New horizons, new opportunities – Knowledge that takes us further!', selected initiatives and projects funded by the BMBF projects were presented to a colorful audience

© H₂Mare/Helke Gehritz

Hydrogen Dialogue, Nuremberg



© H₂Mare



© H₂Mare/Christian Hiemisch

Well attended: the Flagship Projects booth at the Hydrogen Dialogue in Nuremberg

Husum Wind

Kevin Schalk (Fraunhofer IWES) tests the new H₂Mare Game 'Offshore' at the Husum Wind 2023



© H₂Mare/Christian Hiemisch

Next important events

Hannover Messe
April 22–26, 2024, Hannover
<https://www.hannovermesse.de>

H₂Mare Conference
June 6–7, 2024, Berlin
www.h2mare.de

ACHEMA
June 10–14, 2024, Frankfurt am Main
www.chema.de

Project facts and figures

Partners:
32 (plus two associated partners)

Funding level:
over EUR 100 million

Project duration:
April 1, 2021 to March 31, 2025

H₂Mare is one of three Hydrogen Flagship Projects funded by the German Federal Ministry of Education and Research (BMBF) as part of efforts to implement Germany's National Hydrogen Strategy.

Tests on seawater desalination for offshore electrolysis have begun

High-purity water is needed to produce hydrogen by electrolysis. In the offshore sector, however, only saline seawater is available, which has to be laboriously filtered, treated and desalinated before it can be used for electrolysis.

As part of the **H₂Mare project H₂Wind**, scientists at the **Fraunhofer IWES** in Bremerhaven have started initial tests with the aim of investigating the interaction between offshore wind energy, electrolysis and seawater desalination.



Test unit for the seawater desalination plant

The tests are initially focussing on a seawater desalination plant that uses a vacuum distillation process with downstream water treatment. The aim is to define operating points and characterise the system behaviour in order to be able to couple the system directly with an electrolyser at a later stage and test it under real conditions.

for the desalination process in order to significantly increase the turbine, which is dependent on changing wind conditions and control parameters, precise coordination between the desalination plant and electrolyser is crucial.

The coupling should not only supply the electrolyser with sufficient ultrapure water, but also utilise the waste heat from the electrolyser

The tests at Fraunhofer IWES are helping to optimise the technology for the offshore sector, make the use of renewable energies more efficient and thus ensure the energy stability of tomorrow.

Water management for Power-to-X processes

Water is not only required for the production of hydrogen through electrolysis, it also plays a central role in various Power-to-X processes on an offshore platform: as a reaction partner, as cooling water and in the synthesis of energy carriers from carbon dioxide and hydrogen, where it is produced as a reaction product. These aspects of water utilization are being examined in detail and systematically evaluated in the **H₂Mare project PtX-Wind** under the leadership of the **DVGW Research Center at the Engler-Bunte-Institut (DVGW-EBI)** in Karlsruhe and **DECHEMA**. From this, specific treatment processes for all steps of the potential PtX processes are being conceptualised and investigated (seawater desalination, water supply, cooling water, process and waste water).

In order to identify potential uses for excess heat in cooling water for larger platforms (research and production platforms), **DECHEMA** has carried out a heat balance for all PtX processes. It has been shown that these larger platforms have larger quantities of surplus thermal energy available, which offer the potential to optimise the energy balance and efficiency of existing production processes through clever coupling.

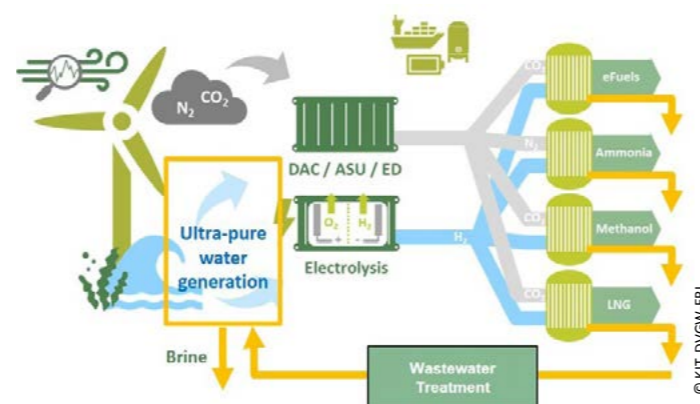

Water cycle on the offshore platform

Energy supply for offshore wind turbines in calm conditions: Which technology is best suited?

The energy supply of a wind turbine must be ensured even when there is no wind, when the wind turbine is not turning and therefore no electricity is being produced. With conventional wind turbines, this is done by connecting them to the power grid. In the **H₂Mare project OffgridWind**, there is no such connection, as the offshore wind turbine is to be used to produce hydrogen and can therefore operate autonomously. The available, self-produced hydrogen is used for the power supply.

In a first step, simulation models of the energy supply system for both energy converters were set up in mid-2023. Various load scenarios were then defined, e.g. for a short and a long, windless period, and calculated using the model. This makes it possible to evaluate the systems in terms of efficiency and hydrogen consumption. Investigations are currently being carried out using the model, with initial results planned for early 2024.

There are two options for using hydrogen to generate electrical energy: the hydrogen combustion engine with a generator and the hydrogen fuel cell. The **Fraunhofer ICT** is investigating which solution is best suited in terms of given requirements such as efficiency, cost-effectiveness and service life.

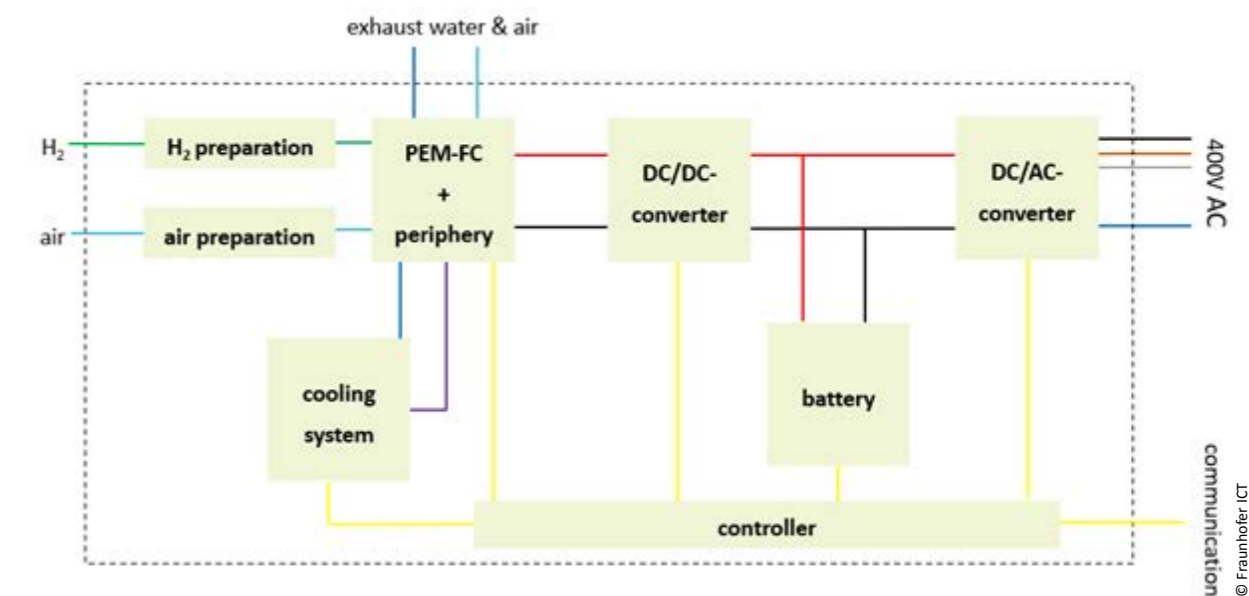

Schematic representation of an energy supply system with fuel cell and battery storage

Our partners supporting

 Flagship Project
H₂Mare

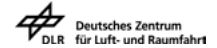

Published by

Technology Platform Office (TPO):

Matthias Müller (Siemens Energy)

Klaus Litty (Fraunhofer IWES)

Heike Gehritz (Fraunhofer IWES)

Christian Hiemisch (Fraunhofer IWES)

Jonas Thamm (Fraunhofer IWES)

This newsletter is published twice a year in English and German.



Visit us

www.h2mare.de



Contact us

h2mare@iwes.fraunhofer.de



Follow us

H₂Mare